

VLA517-01R Specification

Name	HYBRID IC
Type	VLA517-01R
Application	IGBT module drive
Function	Switching, Short-circuit protection

【The intention of printing any notice and caution】

1. The warning about notes, handling notes, and the safety on the specification currently written to specifications are for securing the safety of system apparatus, and cautions are urged to it to the designer of system apparatus.
This does not mean to avoid the responsibility for the accident that has been happened by our failure.
2. In case quality fault or the product trouble occur, we would take the measures and share in the expenses in accordance with a basic contract of dealings and a quality assurance agreement which had been concluded.
In addition, we will determine the case without contract after deliberations separately.

【Please keep "Safety First" in your circuit designs】

1. In using this product for other purposes, please consult with our section responsible for this type.
2. We put the maximum effort into making semiconductor products better and more reliable, but there is the possibility that trouble may occur with them. Trouble with semiconductors may lead to personal injury, fire or property damage. Remember to give due consideration to safety when making your circuit designs, with appropriate measures such as (1) placement of substitutes or, auxiliary circuits, (2) use of non-flammable material or (3) prevention against any malfunction or mishap.
3. When you use it, please refer to notes in "PRECAUTIONS IN HANDLING (FOR SAFETY USING)". Moreover, please do not use for specifications out of the maximum rating or the characteristic of a publication, or a condition.

HYBRID IC (VLA517-01R)	VLA5170103-*	Specifications
------------------------	--------------	----------------

【PRECAUTIONS IN HANDLING (FOR SAFETY USING)】

Great detail and careful attention are given to the production activity of Hybrid IC, such as the development, the quality of production, and in its reliability. However the reliability of Hybrid IC depends not only on their own factors but also in their condition of usage.

When handling Hybrid IC, please note the following cautions.

1 . Packaging

Materials used in packaging Hybrid IC can only withstand normal external conditions. When exposed to outside shocks, rain, and certain environmental contaminators, the packing material deteriorates. Please take care in handling.

2 . Shipping and Handling

- 1) Do not stack boxes too high. Avoid placing heavy materials on boxes.
- 2) Boxes must be positioned correctly during transportation to avoid breakage.
- 3) Do not throw or drop boxes.
- 4) Keep boxes dry. Avoid rain or snow.
- 5) Minimal vibration and shock during transportation is desirable.

3 . Storage

When storing Hybrid IC, please observe the following notices or possible deterioration of their electrical characteristics, risk of solderability, and external damage may occur.

- 1) Devices must be stored where fluctuation of temperature and humidity is minimal, and must not be exposed to direct sunlight. Store at the normal temperature of 5 to 30 degrees Celsius with humidity at 40 to 60%.
- 2) Avoid locations where corrosive gases are generated or where much dust accumulates.
- 3) Storage cases must be static proof.
- 4) Avoid putting weight on boxes.
- 5) When extended storage is necessary, Hybrid IC must be kept non-processed. When using Hybrid IC which have been stored for more than one year or under severe conditions, be sure to check that the exterior is free from flaw and other damages.

4 . Maximum rating

To prevent any electrical damages, use Hybrid IC within the maximum ratings. The temperature, current, voltage, etc. must not exceed these conditions.

5 . Polarity

To protect Hybrid IC from destruction and deterioration due to wrong insertion, make sure of polarity in inserting leads into the board holes, conforming to the external view for the terminal arrangement.

【Others】

This product does not contain the following substance regulated by RoHS compliance.

·Cadmium (Cd), Hexavalent Chromium (Cr6+), Lead (Pb) (Level:phase3A), Mercury (Hg), PBB, PBDE

HYBRID IC (VLA517-01R)	VLA5170103- *	Specifications
------------------------	---------------	----------------

【Equivalent Circuit】

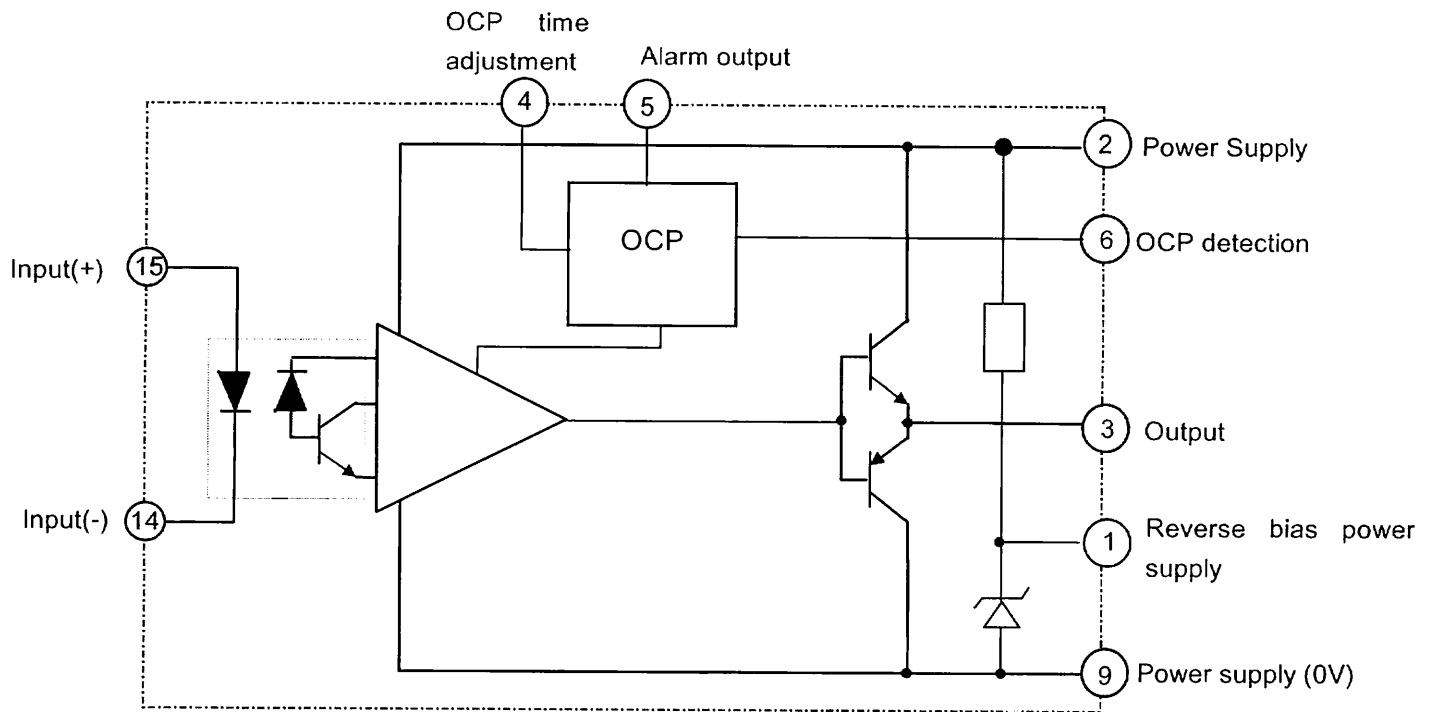

Pin12, 13 are nothing, pin 7, 8, 10, 11 are non connect.

HYBRID IC (VLA517-01R)	VLA5170103- *	Specifications
------------------------	---------------	----------------

【Absolute maximum ratings】 (unless otherwise noted, Ta=25°C)

Symbol	Parameter	Conditions	Ratings	Unit
Vcc	Power supply voltage	-	25	V
Iin	Photo coupler input current	-	25	mA
Ig1	Forward bias output current	PW = 2 μs, duty <= 0.05	4.0	A
Ig2	Reverse bias output current	PW = 2 μs, duty <= 0.05	4.0	A
VISO	Isolation voltage	AC50Hz/60Hz, 1minut	2500	Vrms
Topr	Operation temperature	-	-25 / +60	°C
Tc	Case temperature	-	-25 / +85	°C
Tstg	Storage temperature	-	-25 / +125	°C

【Electrical characteristics】

(Unless otherwise noted, Ta=25°C, Vcc = 20V, Iin= 10mA)

Symbol	Parameter	Conditions	Limits			Unit
			Min	Typ	Max	
Vcc	Power supply voltage	Recommended range	20	-	22	V
Iin	Photo coupler input current	Recommended range	9	10	11	mA
f	Switching frequency	Recommended range	-	-	40	kHz
RG	Gate resistance	Recommended range	1.1	-	-	Ω
VOH	"H" output voltage	-	-	14.5	-	V
VOL	"L" output voltage	-	-	-4	-	V
ton	Switching time 1	-	-	-	1.5	μs
tr	Rise time	-	-	-	1.0	μs
toff	Switching time 2	-	-	-	1.5	μs
tf	Fall time	-	-	-	1.0	μs
Vocp	OCP operating voltage	-	-	8.5	-	V
tocp	OCP delay time	-	-	-	10	μs
tALM	Alarm delay time	-	-	-	1.5	μs
VRB	Reverse bias power supply voltage	-	-	5	-	V

HYBRID IC (VLA517-01R)

VLA5170103- *

Specifications

【Measurement circuit diagram】

Measurement circuit1

Switching operation (t on、 t off)

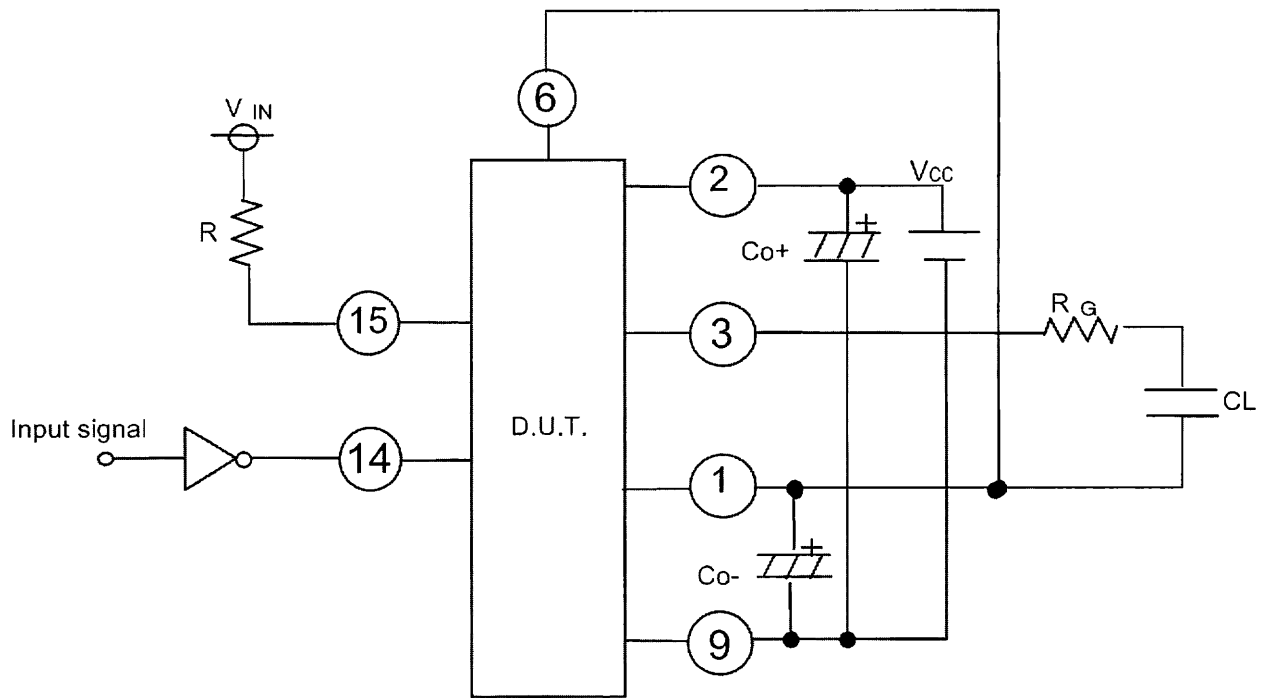

$V_{IN} = 5V$
 $R = 340\Omega$
 $f = 40kHz$
 $D.F. = 50\%$

$V_{CC} = 20V$
 $C_{o+} = C_{o-} = 47\mu F(*)$
 $R_G = 2.7\Omega$
 $C_L = 48nF$

(*) Please mount the capacitor for the voltage amends as much as possible near hybrid IC.

The purpose of this capacitor is to make amends for the voltage descent by the wiring between the drive circuit and the insulation power supply, and no one that smoothness in the rectification power supply was considered.

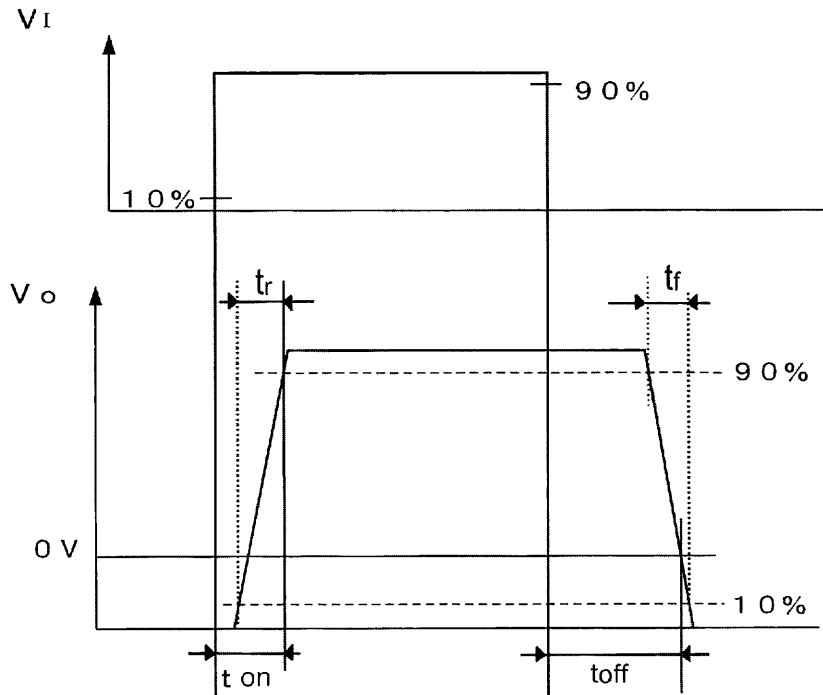

HYBRID IC (VLA517-01R)	VLA5170103 - *	Specifications
------------------------	----------------	----------------

Measurement circuit 2

Vocp, tocp, tALM

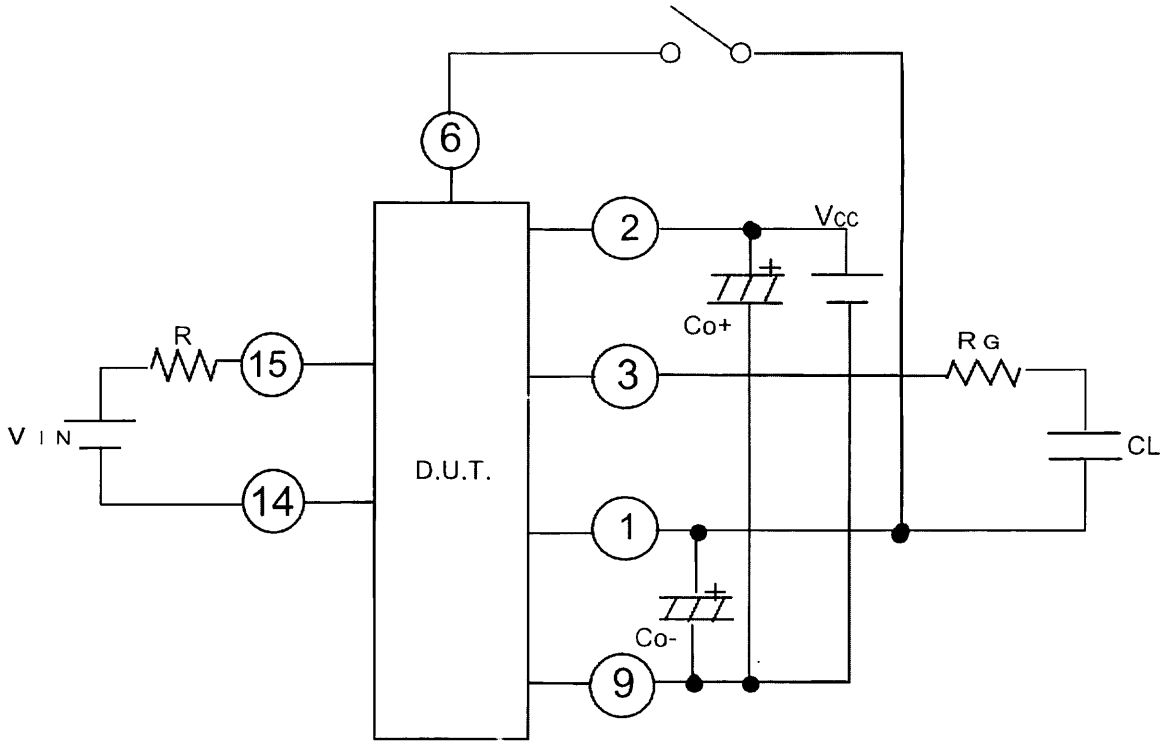

$V_{IN} = 5V$
 $R = 340\Omega$

$V_{CC} = 20V$
 $R_G = 2.7\Omega$
 $CL = 48nF$
 $Co+ = Co- = 47\mu F$

OCP detection

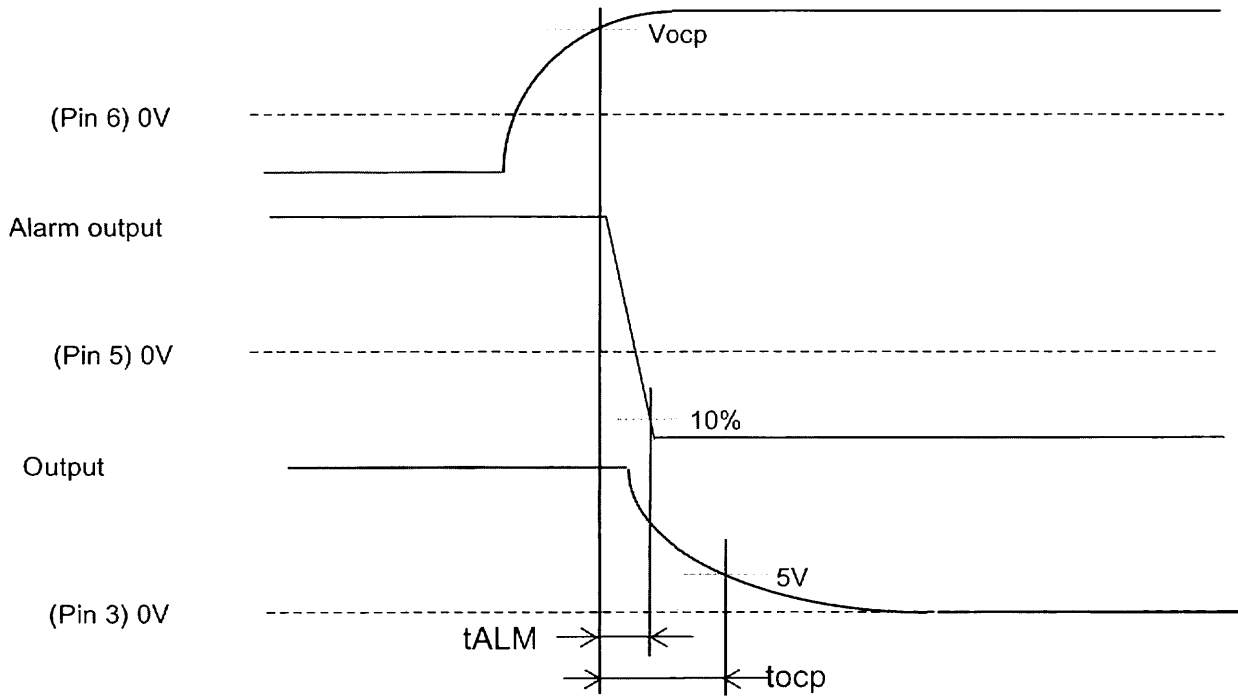

HYBRID IC (VLA517-01R)	VLA5170103 - *	Specifications
------------------------	----------------	----------------

Measurement circuit 3
VRB

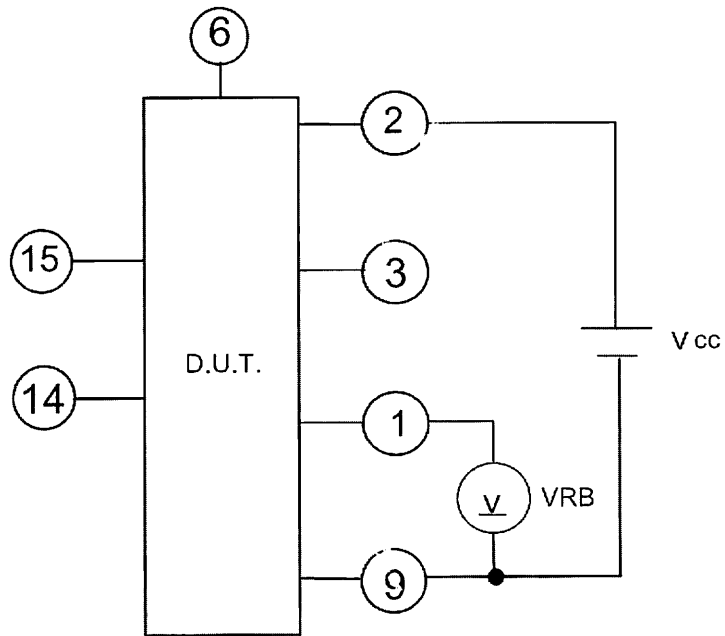

HYBRID IC (VLA517-01R)	VLA5170103 - *	Specifications
------------------------	----------------	----------------

【Reliability level】

In Hybrid IC, the guarantee-of-quality level shown below is applied.

No.	Test item	Test condition	Quality guaranteed level
1	Solderability	[Sn-3.0Ag-0.5Cu Solder used] Solder temperature:245°C,Immersion time:5s. Using a rosin-type flux., Leads immersed up to lead stopper.	LTPD 50%(n=5,AC=0)
2	Soldering heat tolerance	Solder temperature:260°C, Immersion time:10s. Using a rosin-type flux., Leads immersed up to lead stopper.	LTPD 20%(n=11,AC=0)
3	Temperature cycle	Ta= -25°C~125°C, Each 30 min / cycle, 5 cycles.	LTPD 10%(n=22,AC=0)
4	Thermal shock	Ta= 0°C~100°C, Each 15 second / cycle, 5 cycles.	LTPD 10%(n=22,AC=0)
5	Natural fall	75cm, shelf board, 3 cycle	LTPD 20%(n=11,AC=0)
6	Vibration	Frequency: from 10 to 55hz, Peak-to-peak acceleration: 1.5mm Total test time: 6hr., The test time is the same for the x, y and z directions (Body fixed)	LTPD 20%(n=11,AC=0)
7	Tension (leads)	Pulling load: 4.9N(0.5kgf) Load is maintained for 10s.	LTPD 50%(n=5,AC=0)
8	Bending (leads)	Bending load: 2.45N(0.25kgf),loads are applied to the Lead ends. Bending to 90° is done 2 times.	LTPD 50%(n=5,AC=0)
9	High-temperature Storage	1000hr. at Tstg(MAX)	LTPD 20%(n=11,AC=0)
10	Low-temperature Storage	1000hr. at Tstg(MIN),	LTPD 20%(n=11,AC=0)
11	High-temperature Bias	1000hr. at Topr(MAX),	LTPD 10%(n=22,AC=0)
12	Humidity resistance	60°C, 90%, R.H 1000h.	LTPD 10%(n=22,AC=0)
13	High-temperature/ High-humidity Bias	60°C, 90%, R.H 1000hr.	LTPD 10%(n=22,AC=0)

HYBRID IC (VLA517-01R)	VLA5170103-*	Specifications
------------------------	--------------	----------------

【Reflow temperature condition】 (reference)

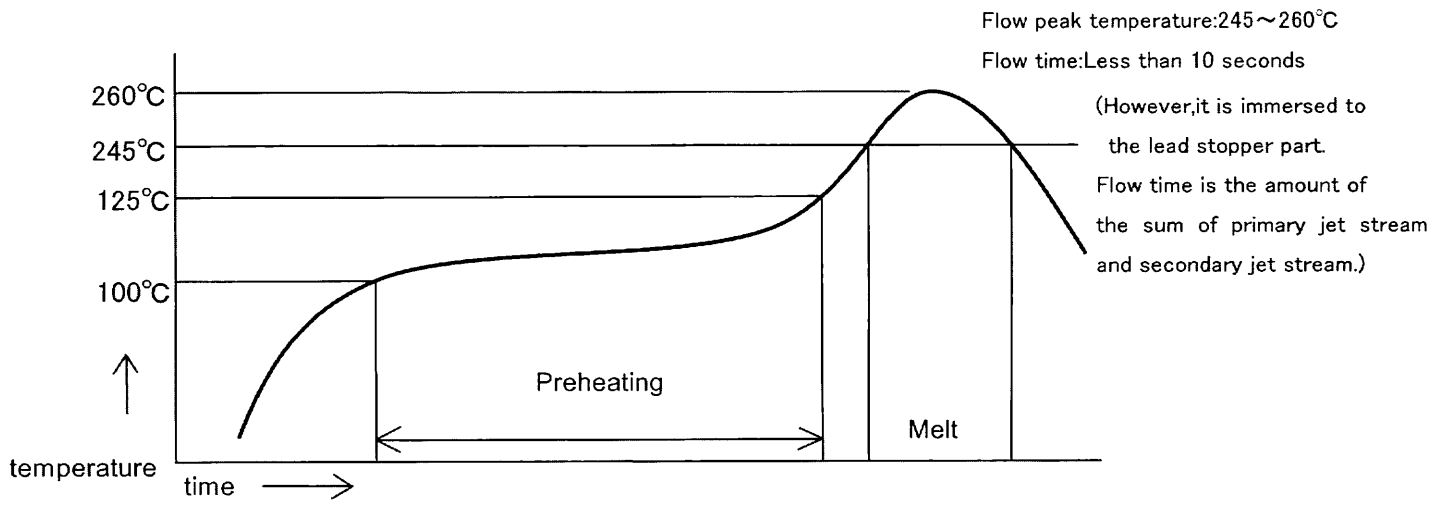

HYBRID IC (VLA517-01R)	VLA5170103-*	Specifications
------------------------	--------------	----------------

HYBRID IC (VLA517-01R)

VLA5170103-*

Specifications

(10 / 10)

Notes

1. Coating resin is black.
2. Coating resin might be adhere to the lead stopper.
3. The pin of No. 12 and 13 are nothing.
4. There are cases that the coating resin has some holes and cracks, though it is not permissible to expose the inner parts.

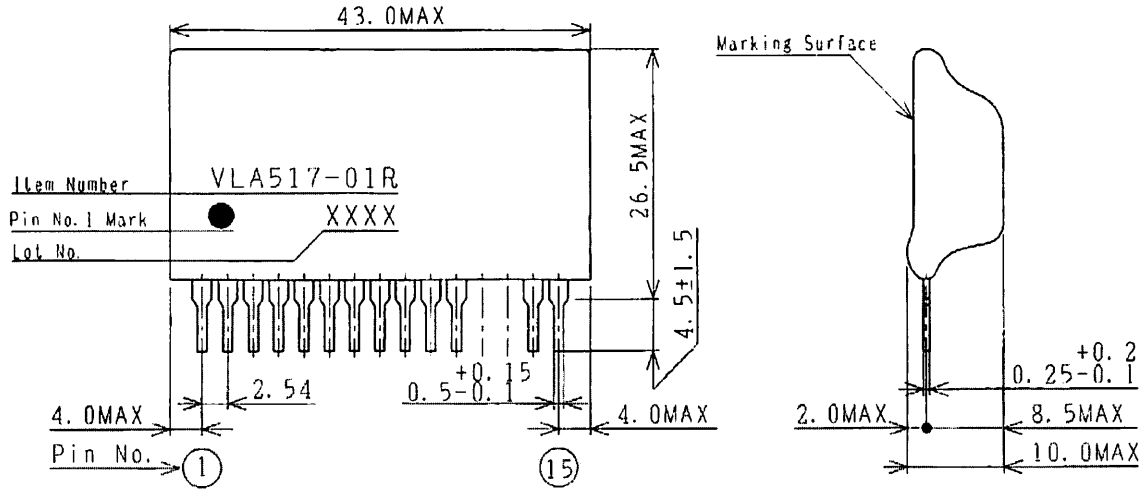

出 図 先		④ 用	第 3 角 法 3RD ANGLE PROJECTION	IAC 一 竹 儿 竹 電 子 株 式 会 社				VLA517-01R
品 保 1	製 造 1	保 留	DIM INmm	作 成 DRAWN	設 計 DESIGNED	照 査 CHECKED	認 可 APPROVED	Outline Drawing
設 計 1		一 時	尺 度 SCALE	2006-05-18	H.Y. Kamada	T. Ito	T. Ito 18. May 2006	VLA5170104
		商 用	作 成 日 付 DATE					

CHANGE

【Outline drawing】